

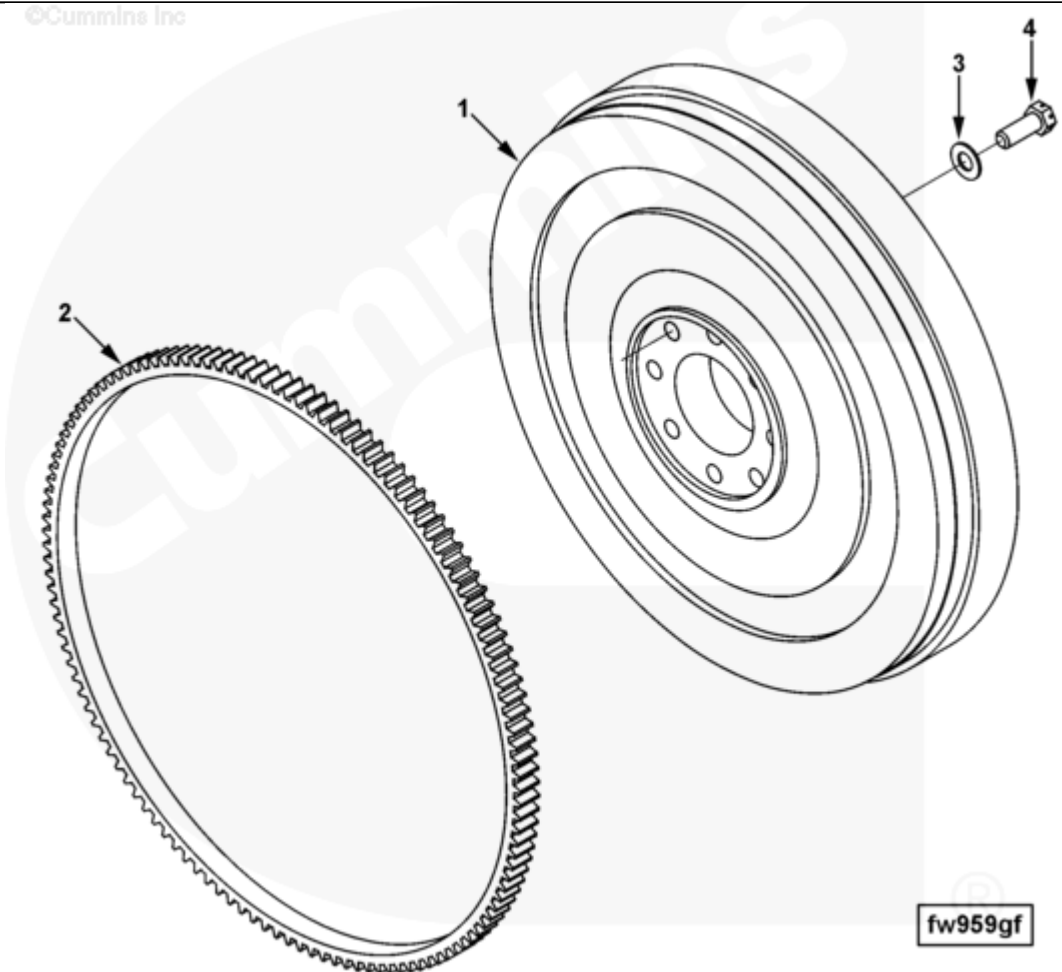

## Parts Catalog - Option Detail

Electronic Parts Catalog - Option Detail				
Option	Group	Graphic	Film Card	Date
FW9232-03	16.02	fw959gf	Z	15-DEC-97
<b>Engines</b>	6C8.3, C GAS PLUS CM556, G8.3, G8.3 CM558, GTA8.3 CM558, ISC CM2150, ISC CM554, ISC CM850, ISC8.3 CM2250, ISC8.3 G CM2180 C101, ISL CM2150, ISL CM554, ISL CM850, ISL G CM2180, ISL8.9 CM2150 L110, ISL8.9 CM2880 L112, ISL9 CM2150 SN, ISL9 CM2250, ISL9 CM2350 L101, ISL9 CM2350 L111, ISLE4 CM850, L GAS PLUS CM556, L8.9, L8.9 L121, L8.9G CMOH2.0 L125B, L9 CM2350 L116B, L9 CM2350 L119B, L9 CM2350 L120C, L9 CM2350 L123B, L9.3 L105, L9.5 L117, L9N CM2380 L124B, QSC8.3 CM2250, QSC8.3 CM2880 C102, QSC8.3 CM554, QSC8.3 CM850(CM2850), QSL9 CM2250, QSL9 CM2250 L115, QSL9 CM2350 L102, QSL9 CM2350 L107, QSL9 CM2350 L118, QSL9 CM2350 L122, QSL9 CM554, QSL9 CM850(CM2850), QSL9 G CM558, QSL9 M CM2250 L106, QSL9.3 CM2880 L113			



[SMALL](#) | [MEDIUM](#) | [LARGE](#)

Cart	Ref No	Part Number	Part Description	Required	Remarks
View My Cart					
		FW9232-03	Flywheel		MR - FLYWHEEL...(More)

				Type: Flywheel
				Housing SAE Size or Type:
				SAE 2
				Intended Drive Hardware: 11
				1/2 in. OC Clutch
				Material Specification:
				41,044
				Ring Gear Pitch: 8/10
				Ring Gear Pitch Diameter:
				438.15mm (17.25 in.)
				Ring Gear Tooth Count: 138
				Crank Flange to Ring Gear
				Leading Edge (mm): 9.075
				Maximum RPM: 3700
				Pilot Bearing Bore Diameter
				(mm): 71.973
				Clutch Mounting Bolt Circle
				(mm): 333.38
				Clutch Mounting Hole Count:
				8
				Clutch Mounting Hole
				Nomenclature: 3/8-16 UNC-2B
				Moment of Inertia (Kg/m2):
				1.17
				Required Starter Center
				Distance (mm): 234.19
				Engine Family: C Series
				Conforms to SAE Housing to
				Wheel Standard: Yes

<input type="checkbox"/>		<a href="#">3282171</a>	Flywheel	1	
	1	<a href="#">3282170</a>	Flywheel	1	
<input type="checkbox"/>	2	<a href="#">3902127</a>	Flywheel Ring Gear	1	
<input type="checkbox"/>	3	<a href="#">3900269</a>	Plain Washer	8	M12
<input type="checkbox"/>	4	<a href="#">3901395</a>	Hexagon Head Cap Screw	8	M12 x 1.25 x 32

© 2019 Cummins Inc., Box 3005, Columbus, IN 47202-3005 U.S.A.  
Terms of Use and Disclaimers | Recommended System Requirements  
Need Assistance? Please click on the Contact Us button in the top right corner of any page.